



Resources Safety & Health  
Queensland

# Guidance note:

## Managing dust ingress into electrical enclosures and equipment

Queensland Coal Inspectorate

14 December 2023 | Version 1

## Contents

Purpose .....	3
Background .....	3
Scope .....	5
Identification.....	5
Assessment and Monitoring .....	6
Control .....	9
General Principles of Dust Control .....	9
Maintenance and Inspection of Dust Controls Systems .....	13
Preventing Dust from Entering the Dragline and Shovel Houses .....	14
Dynavanes.....	15
Floseps .....	18
Cartridge Based Technology.....	18
Electrostatic Precipitators .....	19
Appendix 1: Current Cleaning Practices Requiring Compressed Air and Elimination Options.....	21
Appendix 2: Example of Real Time Monitoring Report .....	23
Appendix 3: Worked Example of the Principles of Dust Controls as applied to Draglines.....	24
Appendix 4: A Worked Example of the Principles of Dust Controls as Applied To Off Road Electric Drive Trucks .....	30
Appendix 5: Ingress Protection (IP) Ratings .....	34
Appendix 6: Example of Dragline Cleaning Process / Sequencing .....	35
Reference List: .....	37

## Purpose

The purpose of this guidance is to provide best practice solutions for preventing dust from entering and depositing in electrical enclosures so that the cleaning of these enclosures may be eliminated or significantly reduced.

This guidance also assists coal mines to reduce exposure to dust to as low as reasonably achievable by providing information on:

- Identifying the common electrical enclosure types that may accumulate dust and require cleaning.
- Current best practices to prevent / reduce the ingress of dust into enclosures.
- Current best practices to remove the build-up of dust that has not been prevented from entering these enclosures.

## Background

Coal mine workers (CMWs) have been using compressed air for maintenance and cleaning tasks routinely over many years. This work is generally conducted by CMW from similar exposure groups (SEGs) including workshop, field maintenance, tyre fitters, laboratory technicians and may also include itinerant workgroups such as shut down maintenance and / or industrial cleaners.

These practices can create airborne dust concentrations well above occupational exposure limits (OELs). In recent years with the introduction of new equipment (e.g. electric drive rear dump trucks) and changes to mining practices (e.g. draglines positioning on low benches in the pit) the frequency of these tasks has increased.

The liberation of this settled dust may expose workers to harmful concentrations of dust (including respirable crystalline silica) that can cause various types of Mine Dust Lung Disease (MDLD) including silicosis.

In particular, the use of compressed air to clean ('blow out') electrical enclosures creates significant quantities of airborne dust. Some of these enclosures are discussed within [Recognised Standard 20 – Dust Control on Surface Mines](#) (RS20) (1). It is important that dust is not allowed to build up in electrical enclosures as it may result in critical failure of components that could potentially result in electrical faults, fire and loss of control of mobile plant (Photo 1).

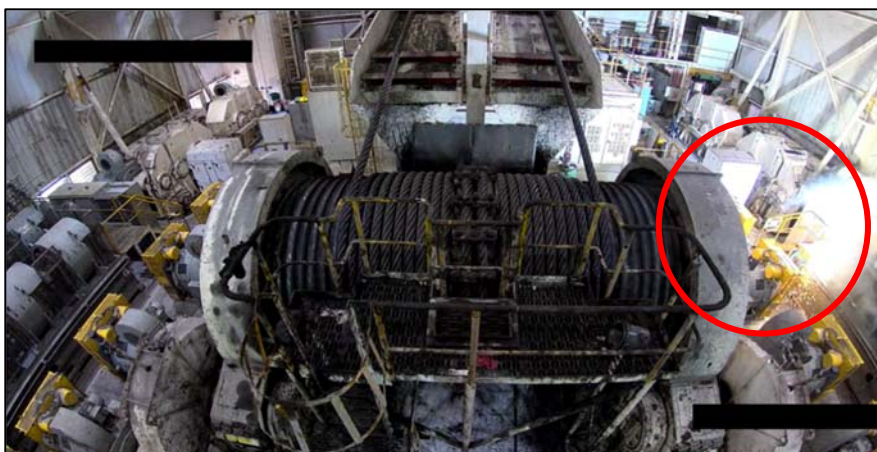

*Photo 1: Dragline Flash Over*

Traditionally there has been an industry acceptance that dust could not be prevented from entering most

electrical enclosures and the only way to protect electrical equipment from these hazards was to use compressed air to routinely clean out the settled dust. There has also been a heavy reliance on respiratory protective equipment (RPE) as the primary control to protect worker exposures.

Typically, these tasks are infrequent and of short duration. However, while these tasks may be relatively short in duration, available exposure data indicates that there is often a very high intensity of exposure that may exceed the design protection factors of respiratory protective devices. A summary of the exposure data during, ‘cleaning of electrical equipment’ tasks has been provided below in Table 1 and Figure 1.

From 1 January 2017 through to 30 September 2023, a total of 313 respirable crystalline silica (RCS) exceedances have been reported for surface mines, with a further 91 respirable coal dust (RCD) exceedances. With further analysis it was determined that 67 of these RCS exceedances (26%) were involved with tasks specifically to remove / clean dust from electrical equipment / components. A significant proportion (30 out of 67 or 45%) of RCS exceedances also returned RCD concentrations in excess of the applicable OEL.

**Table 1: Dust exceedances attributed to cleaning electrical enclosures (Jan 2017 – September 2023)**

Hazards	# Total Exceedances	# Exceedances linked to cleaning dust from electrical equipment	Data Range (mg/m <sup>3</sup> )	Average (mg/m <sup>3</sup> )	Median (mg/m <sup>3</sup> )
Respirable Crystalline Silica	313	67 (26%)	0.03 – 1.1	0.12	0.1
Respirable Coal Dust	91	33 (41%)	1.05 – 63	4.81	3.20

A breakdown of the exposure groups where the exceedances involving cleaning electrical equipment is as follows (Figure 1).

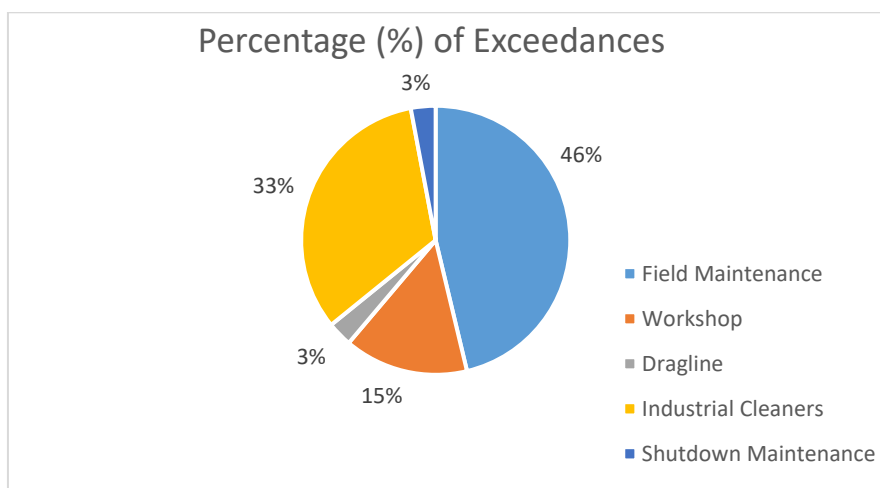

**Figure 1: Distribution of exceedances by SEG (from Table 1)**

There has been limited sampling conducted during these activities, and therefore the data reported above is likely to underestimate the extent of exposure.

Recent industry trials have successfully found alternative solutions that eliminate the need to clean some of these enclosures (or at least significantly reduce the frequency and duration of the cleaning task). Limiting the frequency and duration will have a major impact on reducing worker exposure. In situations where the elimination of compressed air cleaning has not been possible, modification to the cleaning processes, equipment and procedures have been developed by some sites to reduce exposures and reliance on RPE.

## Scope

This guidance is prepared for coal mining operations as defined under the *Coal Mining Safety and Health Act 1999* ('the Act') (2). Some of the practices and controls described may be equally applicable to mineral mines, quarries and other industries.

The scope of this guidance covers the management of dust exposures associated with maintenance and cleaning of electrical enclosures. The primary focus is to provide examples of proven engineering solutions that eliminate, prevent and/ or minimise dust from entering these enclosures. Secondly to provide best practice solutions for reducing airborne dust exposures when required to remove dust that has settled in these enclosures.

It is recognised that there are significant challenges in designing and implementing engineering controls to prevent dust from entering certain electrical equipment such as Motor- Generator (MG) sets on draglines and reactive power compensation (RPC) cabinets on shovels. More effective solutions are being trialled for consideration, and this guidance will be updated accordingly. This guidance details current general principles and available best practice for reducing dust ingress into electrical enclosures and current cleaning practices.

This guidance does not cover other tasks on coal mines where compressed air is used for cleaning and maintenance purposes (e.g. laboratories and tyre bays). In general, the use of compressed air should be eliminated wherever possible and the principles of "Use of compressed air for cleaning" as detailed in RS20 applied (1). These principles include:

- Identifying all tasks requiring use of compressed air.
- Establishing a register of tasks using compressed air use.
- Reviewing controls in place for these tasks with specific focus on the hierarchy of control.
- Monitoring to understand exposure risk and assess effectiveness of controls.
- Reviewing respiratory protection requirements.

## Identification

Some electrical enclosures on coal mines may not adequately prevent dust ingress, which can be further exacerbated if the operating environment around the enclosure is subject to excessive dust generation. These enclosures may be found on mobile and fixed plant at locations including but not limited to:

- Draglines
- Heavy Mobile Equipment (HME) with Electric Drives
- Shovels
- Drill Rigs
- Coal Handling Preparation Plant (CHPP)
- Run of Mine (ROM) Plant

The frequency that these enclosures require cleaning will depend on the effectiveness of the sealing and/ or filtration, pressurisation of the enclosure and the environment in which it is operating. In some cases, the cleaning frequency may be specified by the manufacturer. A detailed list of electrical enclosures, the typical frequency and duration of cleaning has been identified in Queensland Coal Mines and provided in [Appendix 1](#).

Where compressed air is used for cleaning tasks (regardless of the frequency or duration) a register of these tasks must be established and maintained as per the requirements of RS20 (1). This also includes requirements for sites to conduct personal exposure monitoring of coal mine workers conducting any of the registered tasks to ensure controls are effective and do not exceed limits specified in Section 89 of the Coal Mining Safety and Health Regulation 2017 (CMSHR 2017) (3).

## Assessment and Monitoring

Section 49 of the CMSHR 2017 (3) states a mines Safety Health Management System (SHMS) must provide for the periodic monitoring of the level of risk from hazards at the mine that are likely to create an unacceptable level of risk. There are multiple monitoring methods that can be used and may include:

- **Personal exposure monitoring** (gravimetric - quantitative).
- **Investigative and / or task-based dust monitoring** (real time – qualitative).
- **Visual inspection of control performance and condition monitoring.**
  - It is important to visually inspect electrical enclosures on a regular schedule to assess the performance of any existing controls in place, to prevent dust ingress and to ensure dust accumulations do not reach levels that:
    - may increase the risk of electrical fire or failure of critical components.
    - require excessive cleaning (resulting in increased exposure duration).
  - These inspections should be undertaken by persons competent in assessing the dust ingress protection system. The inspections schedule should be based on original equipment manufacturer (OEM) requirements and the site-based inspection history.
  - Excessive dust accumulation should trigger a review of the dust ingress protection system and inspection frequency.
- **Control monitoring** (real time and/ or gravimetric and/ or inspection).
  - Control monitoring is a process defined in Recognised Standard 14 – Monitoring respirable dust in coal mines (RS14) (4). This is a systematic sampling process that has been deliberately designed to allow mines to:
    - investigate the specific sources and/or causes of dust exposure,
    - to validate the effectiveness of new dust controls under trial, or
    - to assess the ongoing performance of existing dust controls.
  - Any monitoring conducted under this format must remain separate from the mines compliance monitoring program but needs to be conducted in accordance with the requirements of RS 14 (4).
  - A control monitoring program will often include a combination of real time and gravimetric monitoring (personal and fixed position).
  - An example of an investigation involving the use of real time monitoring has been provided in Appendix 2.

It is important to understand the objectives of your assessment so that an appropriate monitoring method(s) are selected. This may often include a combination of monitoring methods. A summary of the advantage and limitations of the different methods has been provided in Table 2.

More information around airborne dust monitoring techniques including personal sampling (gravimetric),

fixed position monitoring, real-time monitoring and control monitoring are outlined in RS14 (4).

**Table 2: Summary of Monitoring and Inspection Methodologies**

Type	Advantages	Limitations	Uses
Personal Exposure Monitoring (Gravimetric)	<ul style="list-style-type: none"> <li>– Accurate and validated.</li> <li>– Can be compared directly against OELs.</li> <li>– Sample can be analysed for RCS.</li> <li>– Methods detailed in Australian Standard (AS2985) (5).</li> <li>– Robust equipment.</li> </ul>	<ul style="list-style-type: none"> <li>– Only calculates shift averages.</li> <li>– Cannot isolate dust sources contributing to exposure.</li> <li>– Analysis may take weeks.</li> <li>– May not capture high intensity infrequent tasks due to monitoring schedule.</li> </ul>	<ul style="list-style-type: none"> <li>– Understanding personal exposure.</li> <li>– Seg based programs.</li> <li>– Baseline monitoring programs.</li> <li>– Compliance monitoring.</li> <li>– Control effectiveness.</li> </ul>
Fixed Position Monitoring (Gravimetric)	<ul style="list-style-type: none"> <li>– Accurate and validated.</li> <li>– Methods detailed in Australian Standard 2985 (AS2985) (5).</li> <li>– Sample can be analysed for RCS.</li> <li>– Robust equipment.</li> </ul>	<ul style="list-style-type: none"> <li>– Cannot be compared against OEL.</li> <li>– Analysis delays.</li> <li>– Only calculates average and cannot identify individual dust sources.</li> <li>– Limited sample duration (1 shift)</li> </ul>	<ul style="list-style-type: none"> <li>– Control effectiveness.</li> <li>– Identify source of dust generation.</li> </ul>
Real Time Monitoring (Personal & Fixed Position)	<ul style="list-style-type: none"> <li>– Instant feedback.</li> <li>– Sensitive.</li> <li>– Alarm functions.</li> <li>– Can be paired with simultaneous video footage.</li> <li>– Can log data and provide visual aids (graphing).</li> <li>– Can be used for task-based assessment.</li> <li>– Can be used for extended periods (&gt; 1 shift).</li> <li>– <b>Fixed monitoring</b> identifies the effects from process changes. For example: <ul style="list-style-type: none"> <li>• Control verification</li> <li>• Understanding background levels</li> <li>• Assess clearance time</li> <li>• Can be used to monitor trends over extended periods (ie. &gt; 1 shift).</li> </ul> </li> <li>– <b>Individual real time monitoring</b> assesses the impacts from task and positioning.</li> </ul>	<ul style="list-style-type: none"> <li>– Cannot differentiate silica from other particles.</li> <li>– Can be affected by water vapour.</li> <li>– Cannot be compared against OEL.</li> <li>– Less robust equipment.</li> <li>– Fixed not reflective of personal exposures.</li> <li>– Some level of training will be required to enable effective use of individual devise and interpreting results (eg. sampling interval, alarming functions, calibration, care and maintenance).</li> </ul>	<ul style="list-style-type: none"> <li>– Identifying dust sources and dusty tasks.</li> <li>– Establishing exclusion zones.</li> <li>– Operator training.</li> <li>– Linked to TARP.</li> <li>– Assessing control effectiveness.</li> </ul>
Visual Inspections	<ul style="list-style-type: none"> <li>– Simple.</li> <li>– Quick.</li> <li>– Can be written into inspection protocols.</li> </ul>	<ul style="list-style-type: none"> <li>– Subjective.</li> <li>– Provides no indication of concentration or exposure risk.</li> </ul>	<ul style="list-style-type: none"> <li>– Routine inspection of enclosure for visible signs of dust and status of control integrity.</li> </ul>

**Other parameters that may be monitored:**

When assessing dust generating activities with respect to maintaining and cleaning electrical enclosures, it is often useful to collect other data that may be critical to understanding the pathways of the dust or performance of dust controls. These include but are not limited to:

- **Air movement** – may include measurement of air velocities in the work environment or air velocities measurements within a ventilation system (extraction device) to ensure correct capture velocity. These measurements are typically taken using a hot wire or vane anemometer. (Photos 2 and 3)
- **Air direction** – understanding the direction of air current is important when considering the position of CMWs performing tasks or undertaking adjacent tasks. This can be conducted using smoke tubes, talcum powder or ribbons (Photo 4).
- **Pressure** – It is important to confirm the operating pressure of enclosures designed to prevent dust ingress. These devices may be fixed or portable (Photos 5 & 6). A change in level from the design



pressure may indicate poor sealing or damaged/ blocked filters.

- **Temperature** – Introduction of dust ingress protection systems onto electrical components may compromise airflow and cause an increase in operating temperature. Temperature monitoring devices should be considered.
- **Leaks** – ultrasonic monitoring for leak detection (Photo 7)



Photo 2: Hot Wire Anemometer



Photo 3: Vane Anemometer

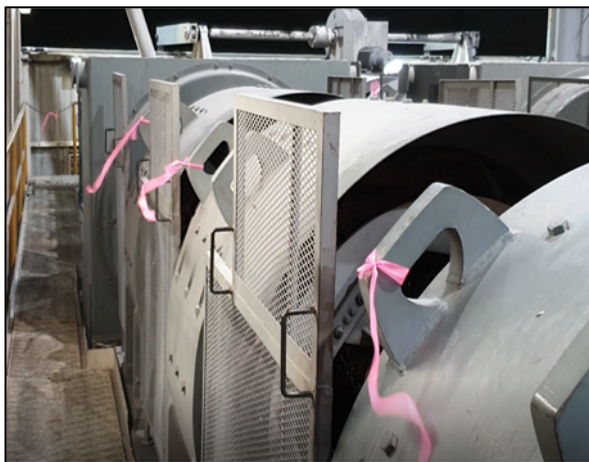

Photo 4: Use of ribbons to show air direction



Photo 5: Pressure Gauge





Photo 6: Pressure Monitoring System



Photo 7: Ultrasonic Leak Detector

## Control

### General Principles of Dust Control

There are typically three opportunities to control dust:

- **Control at source** – prevent dust from entering the atmosphere at source of generation.
- **Interrupt dust pathway** – prevent dust from reaching the breathing zone of workers by:
  - knocking it out of the air (suppression),
  - redirecting it (ventilation),
  - collecting it (filtration), or
  - separation (enclosures)
- **Control at worker** – this is the least effective method as it relies on the use of respiratory protective devices to protect the worker once the dust has entered their breathing zone or reduce the worker's exposure time through task rotation.

These principles are consistent with the hierarchy of control (Figure 2). With Figure 3 displaying how these principles may be applied for electrical cabinets and dragline MG Sets.

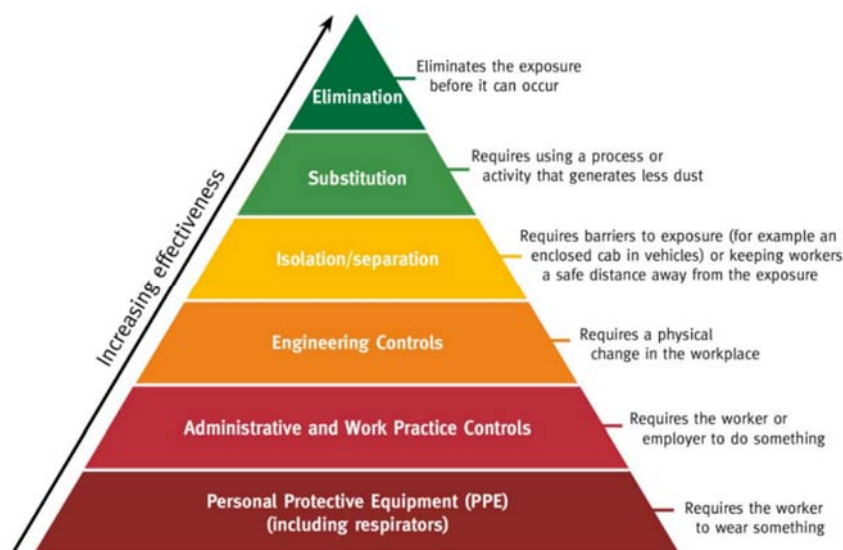

Figure 2: Hierarchy of Controls



Prevent dust generation



Prevent entry into enclosure



Interrupt Pathway (separation)



Respiratory Protection

### DECREASING CONTROL EFFECTIVENESS



### INCREASING EXPOSURE RISK



Prevent Dust Generation



Prevent entry into the house



Separation (remote cleaning)

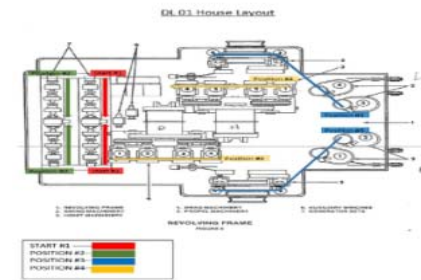

Administration (cleaning sequence)



Respiratory protection

Figure 3

The following section details various dust control measures that can be applied to prevent dust from entering electrical enclosures and/ or limit dust exposure during cleaning. These are detailed in order of effectiveness and should be selected with an objective to reduce exposure to as low as reasonably achievable. Any controls implemented should be assessed for their effectiveness. Examples of these controls applied to draglines and electrical cabinets on trucks have been outlined in [Appendix 3](#) & [Appendix 4](#). Where appropriate, photos of installed / working controls have also been included within the appendices.

- **Preventing / minimising mine dust generation (Eliminate dust)** – minimise dust from becoming airborne in the mine environment. This will limit potential for dust to migrate and accumulate in areas around electrical enclosures. This can be achieved by:
  - Wetting down spoil and coal to be dug / loaded / carted.
  - Using additives on haul roads to bind/ suppress dust.
  - Regular watering of haul roads/ mine roads/ drill pads/ lay down areas and crib park up bays to suppress dust.
  - Mine planning to consider change in operating conditions which may increase dust levels and compromise the effectiveness of the filtration system. i.e. large number of equipment generating dust within the same vicinity may create a heavier loading on filtration systems.
- **Preventing dust entry into electrical enclosures through design (Engineering)** – preventing dust entering the enclosure through Ingress Protection (IP) rating and/or through pressurisation / filtration systems.
  - When constructing/ locating/ designing electrical enclosures consider their placement with respect to minimising exposure to dust from sources of dust generation / external environment.
  - Minimum rating of IP5X\* for electrical enclosures in high dust environments that prevent dust and water ingress through integrity of sealing and construction. Some enclosures that are IP54 rated are being cooled with unfiltered vented air and therefore dust is being introduced, which in turn requires cleaning.

**NOTE:** [Appendix 5](#) provides additional information regarding ingress protection ratings. Second digit “X” can be selected from the range (0 to 6) in the table as per environmental conditions for where the equipment is operating / located. Consider some of this equipment may be required to be hosed down as part of the maintenance process (5).
  - Place electrical enclosures under positive pressure through supply of clean, filtered air. This will significantly reduce the potential for dust to enter the enclosure and therefore reduce frequency and duration of any cleaning required.

**NOTE:** Some electrical enclosures will need air movement for cooling. This must be considered in the enclosure design to avoid overheating and potential for fire.
  - Technological advances which replace equipment that currently require compressed air cleaning such as:
    - AC static control systems on draglines to replace motor generator rotating equipment that requires more frequent cleaning.
    - Closed circuit water cooled systems for use on trucks provide an alternative to air cooling systems at a higher IP rating.

- **Separating CMWs from dust generating tasks (Separation)** – using a physical barrier and /or distance to separate coal mine workers from dust being generated during the cleaning of electrical enclosures.
  - Using temporary covers/ barriers with inlet points to allow compressed air lance to protrude into the enclosure and clean components. The atmosphere inside is then exhausted through a portable extraction unit fitted with HEPA grade filtration.
  - Using remote cleaning process to clean enclosures so that the CMW(s) undertaking the cleaning are located a safe distance from the dust cloud.
- **Modifying the work method process (Substitution)** – modifying the cleaning process to limit the amount of settled dust that can be liberated into the air.
  - Using HEPA vacuum cleaning instead of compressed air and consider cleaning more frequently to ensure deposited dust doesn't accumulate.
  - Using a vacuum to remove settled dust from the enclosure prior to blowing out to limit the duration of compressed air used and the amount of settled dust that can be liberated into the air.
  - Consider the use of extraction ventilation concurrently with the use of air (compressed or otherwise).
  - Where blowing of air cannot be eliminated from the process through the use of higher order controls, select the lowest possible velocity. (e.g. compressed air is typically at 120psi while a handheld air blower is typically less than 0.7psi).
  - Portable vacuum cleaners should comply with the requirements of RS20 and have a minimum HEPA filtration.
- **Administrative controls to limit exposure duration and intensity (Administration)** – reducing exposure duration and intensity by designing the cleaning regime, process and sequence.
  - Using multiple workers to perform the clean to reduce individual exposure time.
  - Reducing time between the cleaning intervals to limit the amount of dust build up within the enclosure.
- **Administrative controls to limit number of CMWs exposed (Administration)** – modifying location and / or scheduling of tasks to limit number of bystander CMWs potentially exposed to dust.
  - Removing all CMWs not involved in the cleaning process from the area impacted by dust generated during the cleaning process.
  - Locating HME to be cleaned away from other occupied areas for the cleaning process.
  - Scheduling cleaning for times when CMWs are not in the vicinity of the enclosure to be cleaned (crib breaks, back shift).
  - Ensure personnel remain out of area until airborne dust has cleared (give consideration to clearance times).
- **Protecting the worker's breathing zone with respiratory protective equipment (RPE)** – use of appropriate RPE during the cleaning process that has been selected, supplied, fitted and maintained as part of the mine's respiratory protection program.
  - RPE should only be used in conjunction with higher level controls after all other options have been considered.

- Specify the use and the type of RPE to be worn in the respective work instructions/ procedures for the duration of clean (including time for airborne dust to settle / disperse). These devices must comply with AS/NZS 1716 (7).
- Ensuring CMWs required to wear RPE are trained in the fitting, storage and maintenance of these devices. This must be part of a respiratory protection program as specified in AS/NZS 1715 (8).
- Ensuring CMWs required to wear negative pressure and tight fitting RPE are facial fit tested in accordance with AS/NZS 1715 (8).
- Ensure that the RPE is readily available and accessible to CMWs. This includes consumables such as replacement filters.
- In the case of PAPR and /or supplied – air systems, these devices should be inspected and serviced in accordance with the OEM recommendations and included as part of the mines scheduled maintenance system.
- The protection factor of the RPE type shall be considered when selecting an appropriate respirator. A minimum protection factor of powered air purifying respirators (PAPR) with P2 class filtration should be considered for any compressed air cleaning task in accordance with RS20 (1).
- As seen in the hierarchy of controls (Figure 2), the use of personal protective equipment is the least effective method of control and should not be relied on as a primary or long-term control solution. It is very important that CMWs are educated about the effective use and limitations of RPE. Reusable RPE, including PAPR should be incorporated into the sites structured maintenance program.

Risks from secondary exposure (exposure to airborne dusts arising from tasks aimed at controlling initial exposure) should also be evaluated. This includes the safe removal and disposal of captured dusts from extraction devices / units without further exposure to workers conducting these tasks. For example, the removal / replacement and disposal / or water-based cleaning of filtration media and grids. Things that need to be considered are:

- Developing a work instruction for that task
- Adjacent activities or CMWs in vicinity
- PPE requirements
- Appropriate disposal of filters to minimise liberation of contaminants.

Where the dust cannot be eliminated from electrical cabinets, cleaning processes should be documented in work instructions and procedures.

## Maintenance and Inspection of Dust Controls Systems

An effective inspection and maintenance scheme is required to ensure equipment designed to manage dust emissions and /or ingress operates as intended on an ongoing basis. Elements to be considered in the development of an effective monitoring / inspection and maintenance plan include:

- Identification of all dust control systems on equipment and plant.
- Establishing the inspection and maintenance requirements for all dust control systems.



- Performance of inspections and maintenance by competent operators and maintainers.
- The early detection of any defect in plant or equipment which could result in a reduced level of operation or protection.
- Enable identified issues and defects to be documented and remedial actions undertaken.
- Scheduled maintenance of equipment to ensure the equipment remains in a fit for purpose state when operating.
- As part of the maintenance program a process must be in place to outline what actions are to be undertaken when one or more of the critical dust controls are not functioning as per design E.g. pressurising unit / system not functioning at required pressure.

## Preventing Dust from Entering the Dragline and Shovel Houses

Some electrical equipment, such as MG sets, located inside the dragline house are often difficult to enclose and protect from dust ingress. Ventilation systems are applied to draglines primarily to provide cooling for the electrical components. These ventilation systems have filtration mechanisms applied to the air intake in order to minimise dust from entering into the dragline house.

The filtration mechanisms applied to the ventilation systems on dragline houses are not designed to remove the respirable sized fraction of dust. The quantity of respirable dust passing through these filters is in proportion to the volume flow through the ventilation system and will deposit and accumulate on surfaces inside the house. This is a significant limitation of these filtration devices. Accumulation of dust inside the house can be mitigated with additional extraction ventilation and filtration systems that can be retrofitted to improve / overcome this limitation. For example, the use of HEPA filtration to target the respirable fraction dusts would be desirable for this application (Photos 8 & 9).



*Photo 8: HEPA Filtration of Dragline House Air*



*Photo 9: Pre-clean Filter*



It is important that these devices are installed, inspected and maintained to optimise their performance. In addition, monitoring the following parameters should be considered:

- Monitoring the house pressure to verify the effectiveness of the ventilation system. Monitoring house pressures can provide information to assist with ventilation system maintenance, operation and efficiency.
- Air flow monitoring within the house area can also assist with optimising the effectiveness of ventilation applied for cooling. The opening and closing of louvres may assist in directing air flow to areas of greater need.

The following sections provide an overview of the filtration systems and discusses their advantages and disadvantages.

## Dynavanes

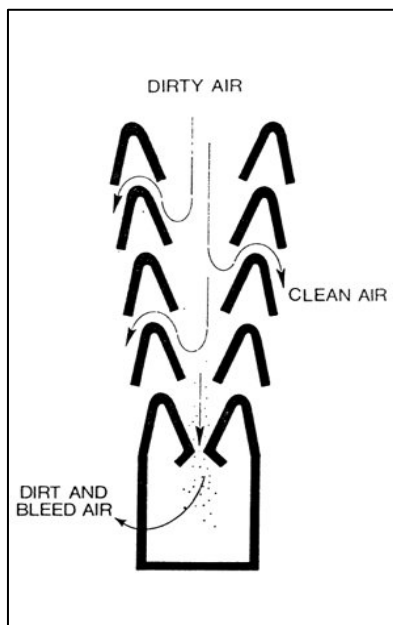

Figure 4: Dynavane Dust Separation (9)



Photo 10: Installed Dynavane

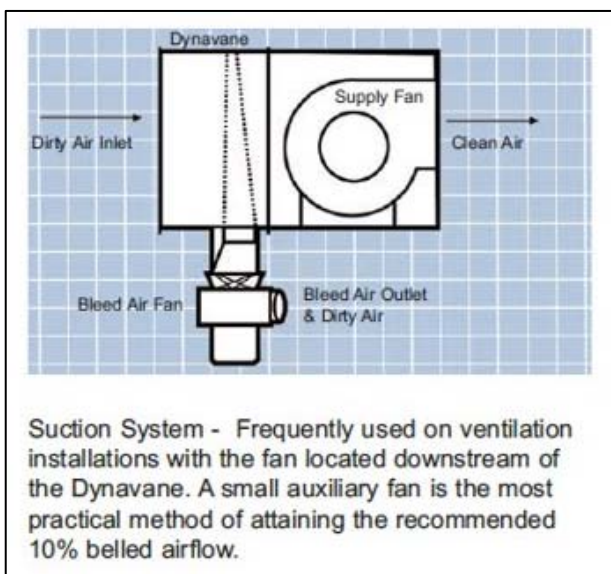

Figure 5: Dynavane Suction System

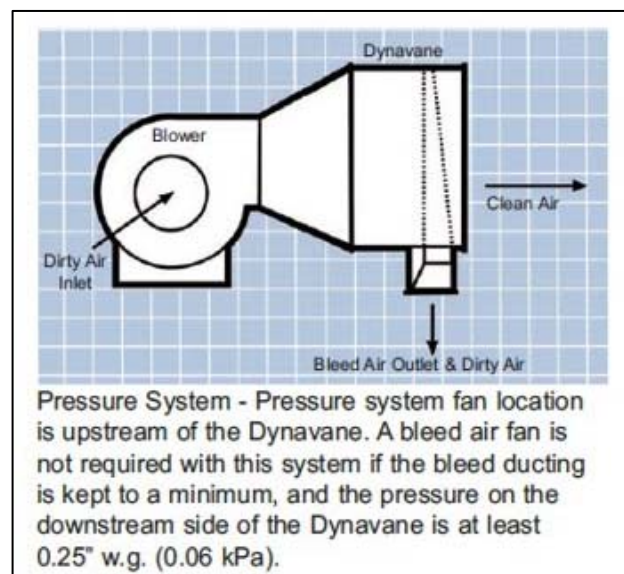

Figure 6: Dynavane Pressure System

Dynavanes are the most commonly used filtration mechanism on draglines and shovels. The fresh air intake containing dust from outside the house is forced or drawn through an element with rear-facing vanes. The air progressively bleeds out through the rear-facing vanes while heavier particles that cannot change direction continue to be captured in a collector. Dynavanes are designed to operate at a constant air velocity. The velocity of air passing through the dynavane system is critical for filtration performance and efficiency. The dynavane must be cleaned regularly to prevent dust accumulation and blockage which results in reducing the air velocity and filtration performance. Figures 5 & 6 shows the two styles of dynavane systems working as either a suction or pressure system setup. Low house pressure can allow prevailing breeze to blow in dust. Low house pressure can also suggest blocked dynavanes or inoperative house fans.

Scavenger fans are used to remove the dust from the dynavane. Scavenger fans are a critical component of dynavane dust filtration efficiency and their maintenance and repair should be a high priority. Radial bladed centrifugal fans running at a slower speed are recommended in preference to axial fans as they are better suited to the high-pressure duty which can result from clogging of the scavenger system.



*Photo 11: Scavenger Fan*

Minimising the lighting around ventilation intake areas or reducing the time lighting is on, greatly reduces insect attraction. Insect debris depositing and accumulating inside the dynavanes is one of the biggest causes of blockages which contributes to poor filtration performance and efficiency.

**Table 3: Advantages and Disadvantages of Dynavanes**

Advantages	Disadvantages
<ul style="list-style-type: none"><li>– Orientation and layout of the Dynavanes can be used to facilitate cleaning.</li><li>– Can handle larger particles more effectively, particularly debris and insects which would otherwise block the system.</li><li>– Low pressure drop across the Dynavanes assist with maintaining house pressure</li></ul>	<ul style="list-style-type: none"><li>– Effectiveness reduces with age.</li><li>– Requires periodic cleaning for continued good performance.</li><li>– Not as effective at removing small particles, generally limited to &gt;1 micron (7)</li><li>– Susceptible to blockages, however when blocked, dusty air can still be supplied to maintain house pressure</li></ul>

### Further Recommendations

- Regular cleaning of the Dynavanes and scavenger fans is essential for maintaining filtration performance. Without regular cleaning the filtration efficiency drops off significantly. Dynavanes can be oriented to allow easier access or removal for cleaning. Cleaning of the filter panels, maintaining rubber seals and airway intake slots are critical for an effective cleaning regime (Photo 12). Dynavanes can be replaced with new blade packs and seals to return performance to original design.

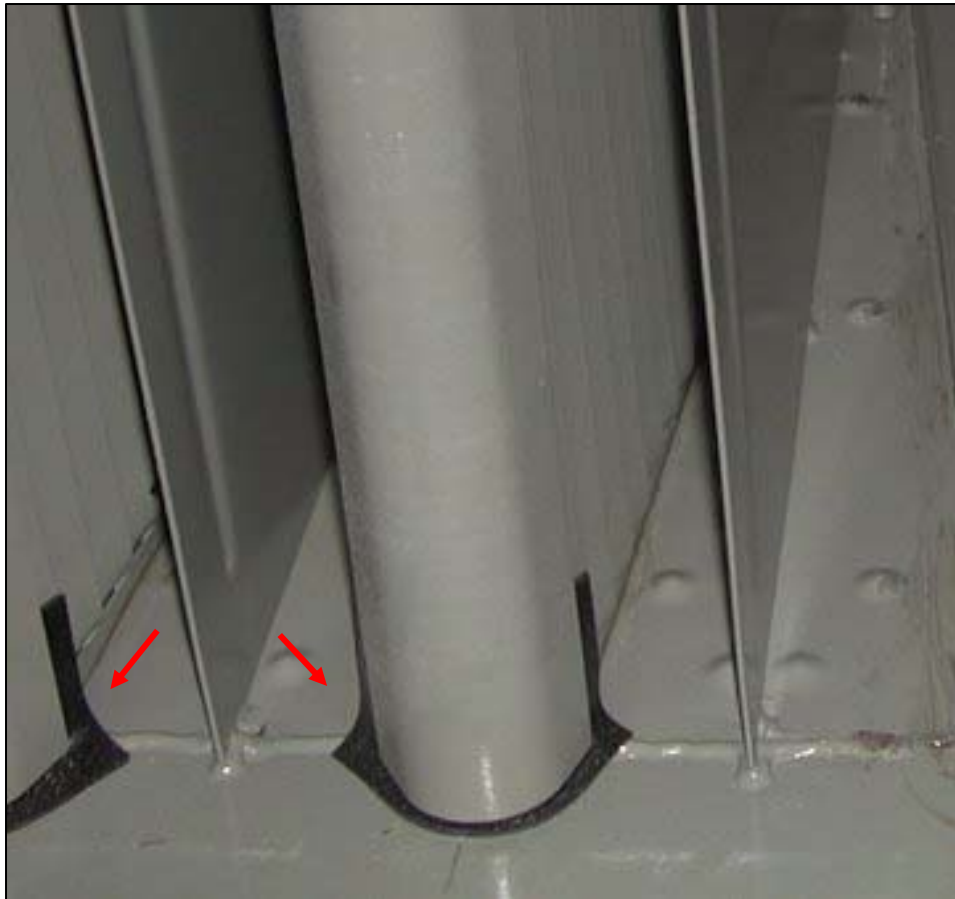

*Photo 12: Blade Pack Seals*

- The use of a mesh screen (preferably 6mm) to prevent large debris and insects from entering the system is recommended. Adequate separation distance between the mesh and dynavane intake is required to sufficiently reduce the air velocity across the screen surface area, to below the velocity required to capture insects and debris. Velocity below 5 m/sec is recommended to minimise insect capture. In addition, protection from water, such as that provided by rain hats or enclosed rooms

surrounding the intake area, prevent blockages and improves the life of the dynavane. The intake mesh screen should be cleaned and maintained regularly to prevent blockages and loss of filtration efficiency.

- Consideration should be given to reducing the number of fans operating during cooler months of the year when lower ambient temperatures reduce the requirement for cooling ventilation into the house. Reducing the total ventilation volume entering the house when cooling is not required, reduces the net quantity of dust entering the house during this period.

## Floseps

Floseps are a type of centrifugal dust separator and have the advantages of compact size and better removal of small particles. Rotation of airflow through the individual tubes force dust particles to the outside of the flow due to centrifugal force. Dust then collects and slides down into a hopper which can be emptied.

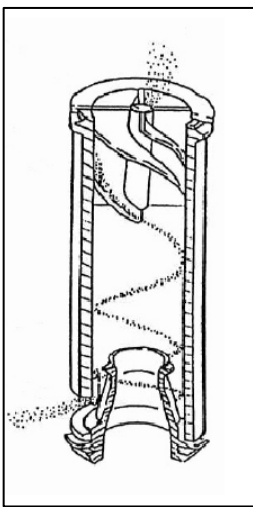

Figure 7: Individual Flosep device (9)

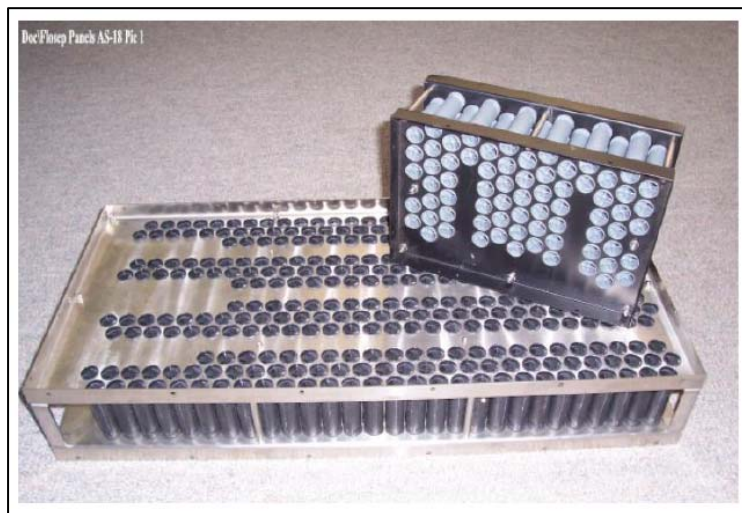

Photo 13: Flosep panels comprising multiple individual tubes (picture supplied by Flosep Dust Filtration Australia) (9)

**Table 4: Advantages and Disadvantages of Flosep**

Advantages	Disadvantages
<ul style="list-style-type: none"> <li>– Relatively compact size</li> <li>– Effective at removing larger particles</li> <li>– Can remove smaller particles than Dynavanes</li> </ul>	<ul style="list-style-type: none"> <li>– Susceptible to blockages from large debris and insects</li> <li>– Blockages have a significant impact on filtration efficiency.</li> <li>– When blocked, air cannot pass into the house &amp; house pressure may not be maintained</li> </ul>

## Cartridge Based Technology

Cartridge technology is a variation on traditional baghouse filtration where the bag style filters are replaced with more compact cartridges. This could potentially reduce the size of a baghouse option on a dragline from approx. 8m to 6.5m in height, saving on space (10). Currently cartridge technology is used on electric rope shovels and fixed plant but could be adapted to suit draglines.





Photo 14: Cartridge / Baghouse Technology on Shovel (10)

Table 5: Advantages and Disadvantages of Cartridge based technology.

Advantages	Disadvantages
<ul style="list-style-type: none"> <li>Overall efficiency is high – P&amp;H AirScrubPro™ has been measured at 98.9% efficiency on average (8)</li> <li>Can filter significantly more particles, including particles less than 1 micron.</li> <li>Use of automatic pulse jet cleaning makes cartridge filtration self-cleaning and not affected by insects &amp; debris.</li> <li>Layout promotes relatively easy replacement of cartridges</li> </ul>	<ul style="list-style-type: none"> <li>Size: large footprint would need to be accommodated on top of the dragline house, along with sufficient height</li> <li>Weight: a suitable system could weigh up to 100t on a 8050 dragline, structural support may be required (8).</li> <li>Greater pressure drops across cartridges and higher power consumption as a result.</li> </ul>

## Electrostatic Precipitators

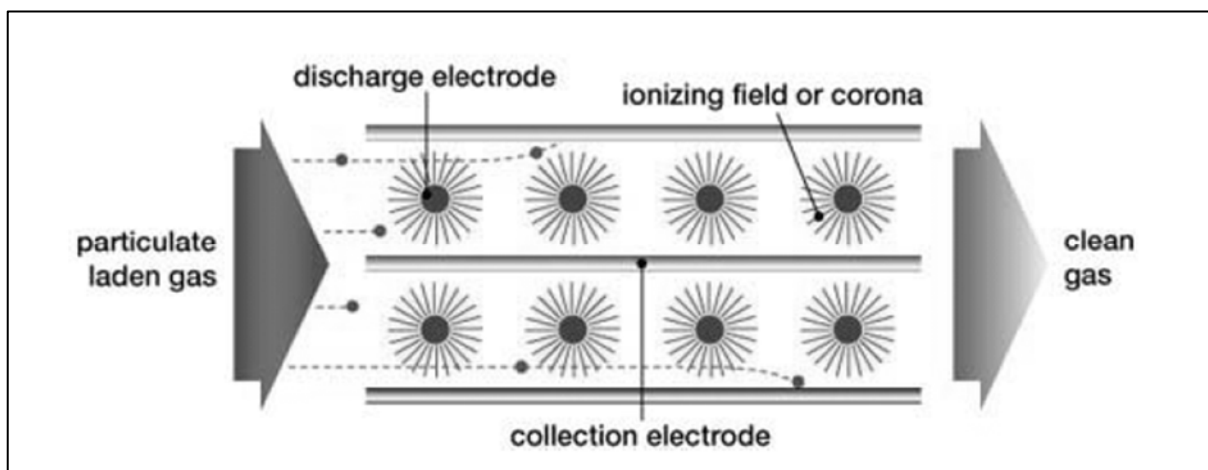

Figure 8: Example of electrostatic dust precipitation (10)

Electrostatic precipitators ionise the dust particles in an air stream then pass the air through a series of oppositely charged collection plates. This technology is largely used in industries with very fine particles, such as mills, and coal fired power stations.

**Table 6: Advantages and Disadvantages of Electrostatic Precipitators**

Advantages	Disadvantages
<ul style="list-style-type: none"><li>- High collection efficiency, up to 99.9% (9).</li><li>- Effective at collecting fine dust particles</li><li>- Plates can be cleaned and reused rather than replaced</li></ul>	<ul style="list-style-type: none"><li>- Relatively high cost</li><li>- Not effective for materials with very high or low resistivity</li><li>- Large size – larger than baghouses / cartridge units</li><li>- In heavy dust, collection plates fill up quickly</li></ul>



## Appendix 1: Current Cleaning Practices Requiring Compressed Air and Elimination Options

Type of HME / Plant	Component Requiring Cleaning	Approx. Frequency of cleaning	Approx. Duration of task	Number of CMWs involved	Options available to <u>eliminate or reduce cleaning</u>
Komatsu 830E, 930E trucks	HV Cabinet DC Grid blower motor	Blowout every 250 - 500 hours Occasional vacuuming may be required	30 mins	1	After-market (retro-fitted) HEPA filtration / pressurisation fitted to cabinets. Filters changed every 3000 Hr. Cabinets inspected every 500 hrs
Hitachi EH4000 trucks	HV Cabinet / drive system	Vacuumed every 500 hours	30 mins	1	
	Alternator terminal box	Vacuumed every 2000 hours	30mins	1	
Hitachi EH4500 trucks	HV Cabinets AC Grid blower motor	No blowout required Occasional vacuuming may be required	30 mins	1	OEM supplied filtration / pressurisation fitted to cabinets. Filters inspected / changed every 250-500 hours.
Hitachi EH5000 trucks	Liquid cooled drive system HV Cabinets AC Grid blower motor	No blowout required Occasional vacuuming may be required	30 mins	1	OEM supplied filtration / pressurisation fitted to cabinets. Filters inspected / changed every 250-500 hours.
Caterpillar AC Drive truck	Drive system HV Cabinets AC Grid blower motor	Vacuum cleaned every 500 hours	1 hour	1	OEM supplied pre-cleaner / pressurisation system fitted on outside of cabinet. Inspected every 500 hours
Leibherr AC drive trucks	Liquid cooled drive system HV Cabinet with filtered pressuring fan	Vacuum cleaned every 500 hours	1 hour	1	Pressurising Fan and filter on outside fitted to cabinets
	AC Grid blower motor	Vacuum cleaned every 500 hours	1 Hour	1	Vacuum cleaner. On-Board fan for cooling only
Shovels	RPC & Convertor cabinets only	Monthly inspections / filter changes	20 mins	2	Ensure large openings for electrical cables / hoist ropes are minimised i.e. rubber sheeting, rope brushes and spray foam. After-market baghouse filtration systems for electrical control rooms.

Type of HME / Plant	Component Requiring Cleaning	Approx. Frequency of cleaning	Approx. Duration of task	Number of CMWs involved	Options available to <u>eliminate or reduce cleaning</u>
Dragline DC Drive	MG Sets	Blowout Fortnightly - Monthly	Up to an hour	2	Maintenance of house filtration system i.e. dynavanes Separate extraction / HEPA filtration system applied to dragline house Pre-vacuum MG sets to remove dust from stator and armatures prior to blow out
	Motors consisting of propel, swing, drag, hoist motors				Individual blowers on motors to provide cooling and minimise dust depositing. Some sites do not blow out these motors.
	Control panel cabinets	Fortnightly - Monthly	Up to 5 mins	1	After-market (retro-fitted) HEPA filtration / pressurisation fitted to cabinets.
AC Drive Dragline	Drive Packages	Vacuum clean 24 Weekly	90 mins	1	
	AC motors	NA	NA	NA	Not required. Enclosed system
ROM Feeder drive motor	Armature	Monthly	30 mins		

## Appendix 2: Example of Real Time Monitoring Report

Site	Coal Mine	Real-Time Graph						
Sample Date	21 March 2023							
Location	Mobile equipment shutdown pad							
Plant/ Equipment	Cat/Komatsu/Liebherr dump truck							
Plant Identification	RDT #35							
Real-time Sampling Equipment ID	Real time dust sampler # 03							
Paired Gravimetric Sampling ID	Respirable dust cyclone # 21							
Sampler location	Person conducting blowout							
Respiratory Protection	Disposable P2 respirator							
Objective	Verify dust control effectiveness							
Activity	Trial: Blow out electrical cabinets using PLev extraction ventilation system							
Dust controls	PLev System - Enclosure panel placed over electrical cabinet. Local extraction ventilation applied to enclosure. Compressed air lance inserted through slots in enclosure panel. Pressure inside enclosure monitored							
Real-Time Task Based Measurements								
Task Breakdown (including observations)	Start Time (HH:MM)	Task Duration (HH:MM)	Average Conc. (mg/m3)	Max Conc. (mg/m3)	Total Sample Time (HH:MM)	Average conc. (mg/m3)	Gravimetric Sample Resp Conc. (mg/m3)	Photos
Set up screen	14:01	00:20	0.04	0.3	02: 29	0.04	0.27	 Photo 1 Photo 2
Invertor cabinet 1 set-up and blowout set-up (photo 1)	14:21	00:19	0.04	0.17				
Invertor cabinet 2 set-up, blowout and pack down	14:40	00:10	0.13	0.81				
Reinstalling cupboard seals on invertors (photo 2); setting up for GFS, commences blowout at 14:51. Finishes blowout at 14:57	14:51	00:10	0.10	1.09				
Setting up for Rectifier (AFSE). Commenced blowout at 15:03, Finished blowout of AFSE at 15:06. Cabinet closed at 15:09	15:01	00:08	0.06	0.3				
ICP - Set-up clean from 15:09. Commenced blowout at 15:12 (photo 3). Finished blowout at 15:14. Clean cabinet prior to blowout. Cabinet closed at 15:16	15:09	00:07	0.04	0.12				
24V cabinet - Set-up from 15:16, commences blowout at 15:21. pLEV overheating issues experienced. Finished blowout 15:30	15:16	00:14	0.02	0.38				
Transformer - set-up from 15:30, Very dusty internally. Commences blowout at 15:35 - negative pressure issues, rearranges plastic, Finishes at 16:00	15:30	00:35	0.04	0.4				
Alternator side 1 - Set-up. Commences blowout at 16:17 (photo 4)	16:05	00:14	0.01	0.03				
Alternator side 2 - Set-up. Commences blowout at 16:21	16:19	00:06	0.01	0.015				
Final pack-up	16:25	00:06	0.02	0.43				 Photo 3 Photo 4

## Appendix 3: Worked Example of the Principles of Dust Controls as applied to Draglines.

### PREVENTING / MINIMISING MINE DUST GENERATION (ELIMINATE DUST)

- Location / placement of dragline (consider air intake)
- Wetting down spoil and coal to be dug to minimise dust from becoming airborne in the mine environment.



*Photo 15: Wetting of blasted material*

### PREVENTING DUST ENTRY INTO ELECTRICAL ENCLOSURES THROUGH DESIGN (ENGINEERING)

- House ventilation with dynavane filtration system  
**Note:** The size and weight of alternative filtration media including cartridge style systems currently available, that would be required to filter the ventilation volumes typically used on draglines, precludes their application in practice. They have been effectively applied to smaller equipment including shovels, where the ventilation capacity required is approximately five times less.
- As a minimum, sites should:
  - Meet the OEM or aftermarket design specification for operation.
  - Continuously monitor house pressure with set trigger levels to initiate actions to follow where pressure is outside acceptable ranges.
  - Ensure filtration and pressurisation systems remain operational throughout all mining activities that generate dust.
- To reduce insect and debris capture, pre-cleaning mesh (6mm) screen applied to protect the ventilation intake stream, positioned at sufficient separation distance and surface area of screen chosen to achieve velocity across screen (below 5 m/sec).
- Regular cleaning of pre-cleaning mesh screens to remove bulk debris and prevent build-up blockage.





Photo 16: Pre-Cleaning mesh

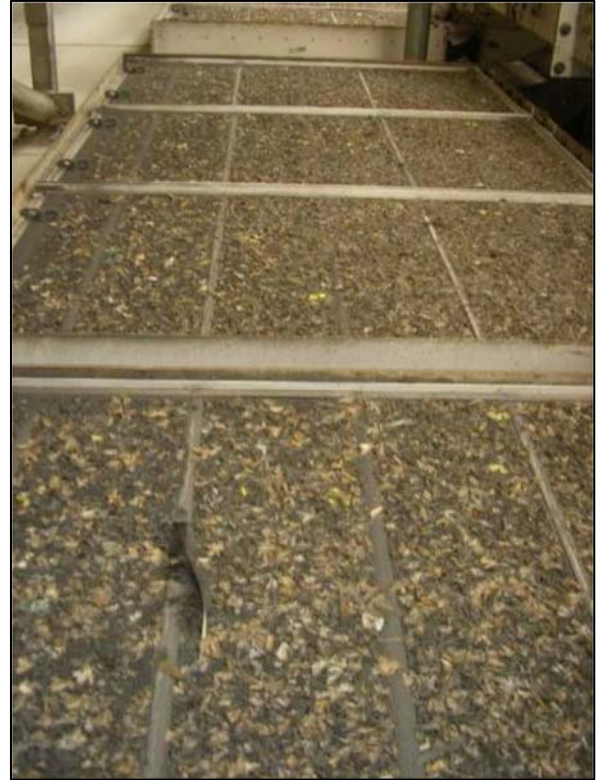

Photo 17: Clogged Pre-mesh on Intake

- Lighting - Selection and position of lighting to limit attraction of insects around ventilation intakes.
- Consider directional change of air through intake air filtration to facilitate larger particles to impact and 'drop out' of system (gravity assisted ACARP 15030 (9)).

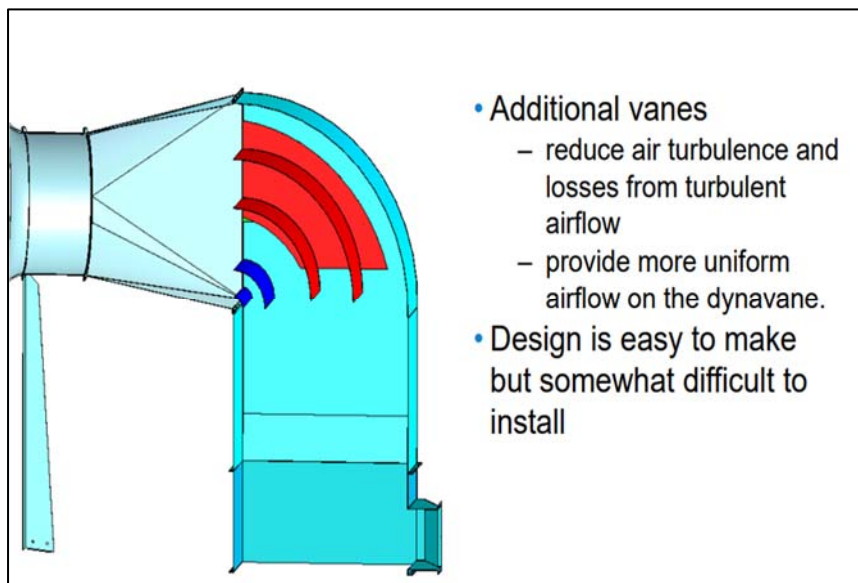

Figure 9: Directional change through intake

- Maintain and monitor in house pressurisation levels to OEM design guidelines where available (or minimum 75 Pa). This prevents inward leakage of dust due to venturi effect on downstream surfaces relative to external wind speed and direction and movement of dragline. House pressure trends provide indication of ventilation system performance and early indication of system failure (dynavane blockage or excessive house leakage).
- Dynavane banks completely removed from dragline roof for cleaning. Slot entry to scavenger circuit

thoroughly cleaned after banks removed. Seals to dynavane bank seating checked and maintained to prevent bypass leakage. Redundant set of dynavane banks installed to facilitate continued dragline operation during cleaning of removed banks.



Photo 18: movable intake hood for easy access to dynavanes for cleaning



Photo 19: Access hatch to dynavanes for cleaning

- Major design upgrades:
  - Consider dragline engineering upgrade to AC operation which have switchboards instead of DC motor generators, to coincide with next major overhaul. This reduces the cooling capacity required from house ventilation and enables opportunity to have enclosed IP rated switchboards that prevent dust ingress and eliminates the requirement to clean.



Photo 20: AC Drive Dragline

- Installation of additional extraction ventilation system with filtration mechanism to capture respirable particles from the house air, to compensate the deficiencies of current dynavane filtration systems to effectively capture the smaller size fraction.





Photo 21: HEPA filtration system for dragline house



Photo 22: HEPA filtration system for dragline operator Cab

### SEPARATING CMWS FROM DUST GENERATING TASKS (SEPARATION)

- Trials ongoing to enclose electrical equipment with separate ventilation / filtration / pressurisation system during cleaning (e.g. Temporary enclosures with inbuilt HEPA extraction).
- Remote controlled cleaning system with CMWs located in fresh air environment. Consideration should be given to ensuring that the design of the compressed air discharge/delivery achieves the same cleaning efficiency as the use of manually operated lances.

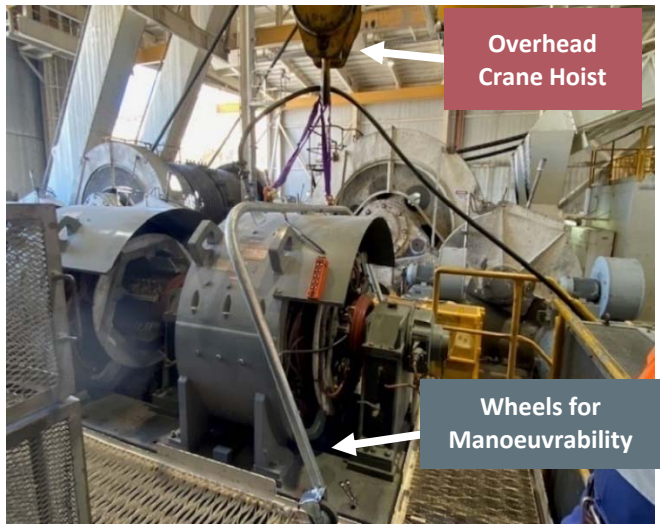
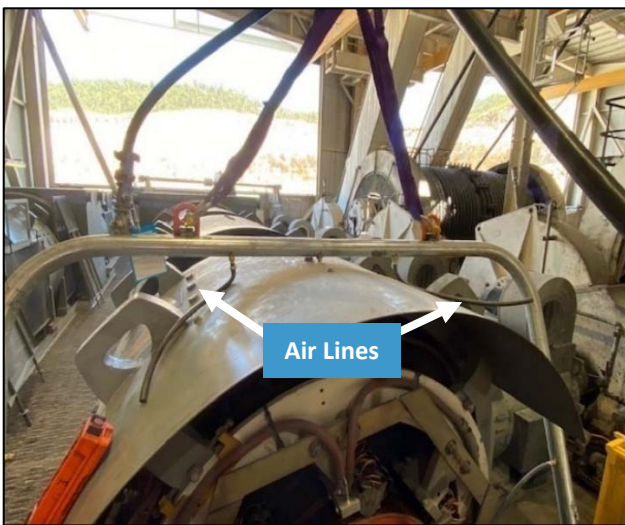

Photos 23 & 24: remotely operated dust agitator with compressed air line for MG sets suspended from overhead crane

## MODIFYING THE WORK METHOD PROCESS (SUBSTITUTION)

- Pre-vacuum to reduce amount of dust (e.g. Using Vac-truck or portable vacuum system with HEPA filtration) prior to compressed air cleaning.



Photo 25: HEPA Vacuum Cleaner

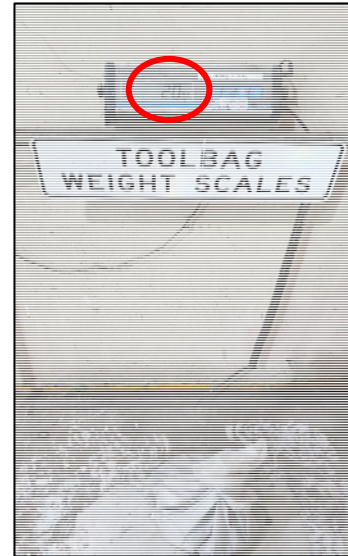

Photos 26 & 27: Example of amount of dust collected during pre-vacuum of a set of six generators in a Dragline that would have previously been 'blown out' (approx. 2 kgs)

## ADMINISTRATIVE CONTROLS TO LIMIT EXPOSURE DURATION AND INTENSITY (ADMINISTRATION)

- Consider the sequencing when using compressed air, by working methodically from the front to the rear of the house to direct the dust in the same direction and out of the house and avoid being in the line of fire of liberated dust.
- Consider doors open and doors closed – with doors closed air will follow design ventilation flows and be more predictable, whereas with doors open this will create dead areas of flow and be less predictable. Approach should be documented in a safe work instruction for repeated activities.
- Monitor and consider air flow movement inside draglines and include air flow directions in the development of work instruction for the blow out process.
- Run the house fans during blowout to direct the flow of dust generated outside the house.
- Once the blowout is finished, allow time for the house ventilation filter units to further reduce respirable airborne dust before allowing other CMWs to re-enter the house (clearance time).
- A real-time monitor may be used to compare and verify pre & post dust levels for clearance monitoring and the impacts of having doors open vs shut during the clean (consideration should also be given to external wind conditions).
- Consideration of equipment being used for dust extraction thereby increasing distance between the CMW and the dust source e.g. extended lance.

## ADMINISTRATIVE CONTROLS TO LIMIT NUMBER OF CMWS EXPOSED (ADMINISTRATION)

- Apply exclusion zones / times to remove all CMWs not directly involved in the task from the dragline house during blowout.
- Limit the time an individual CMW is exposed by rotating CMWs who perform the blowout activities.

- Consideration to be given to dragline positioning on maintenance days in relation to other occupied areas (e.g. Crib huts).

#### **PROTECTING THE WORKER'S BREATHING ZONE WITH RESPIRATORY PROTECTIVE EQUIPMENT (RPE).**

- Ensure all RPE complies with AS/NZS 1716 (7).
- Use a minimum of PAPR or supplied air respiratory protection when using compressed air for cleaning without using extraction ventilation as per RS20 (1).

#### **MAINTENANCE OF CONTROLS**

- Implement a maintenance and inspection schedule for the house filtration system to ensure it achieves design performance and OEM performance requirements.
- Maintenance triggers should be established based on performance monitoring (e.g. TARP with number of fans operating or loss of house pressure).
- Scheduled inspection and maintenance of RPE to OEM requirements (PAPR).



## Appendix 4: Worked Example of the Principles of Dust Controls as Applied to Off Road Electric Drive Trucks

### PREVENTING / MINIMISING MINE DUST GENERATION (ELIMINATE DUST)

- Wetting down roadways to minimise dust from becoming airborne in the mine environment. This will limit potential for dust to migrate and accumulate in areas around electrical enclosures.



Photo 28: Water truck to mitigate roadway dust

### PREVENTING DUST ENTRY INTO ELECTRICAL ENCLOSURES THROUGH DESIGN (ENGINEERING)

- Fitting electrical cabinets with positive pressurisation and HEPA filtration systems to minimise dust ingress.

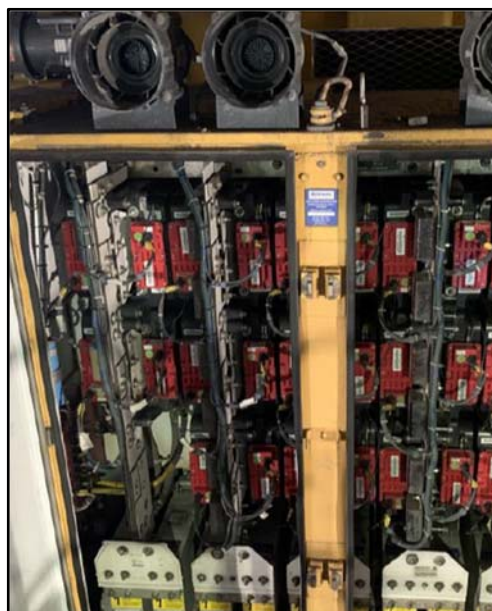

Photos 29 & 30: HEPA Filtration and pressurisation unit fitted to electrical cabinets

- The IP ratings of enclosures is an important aspect of design.
  - As a minimum must meet and maintain the OEM design specification for operation.
  - Filtration and pressurisation systems to remain operational throughout all mining activities.
  - Monitoring of cabinet pressure would be beneficial, in conjunction with alarm triggers, where pressure falls outside acceptable ranges.

- Regular cleaning of filters as specified in the maintenance program.
- Technological advances
  - Consider engineering design concepts such as closed loop water cooled systems which greatly reduces the necessity for larger volumes of air to provide cooling.

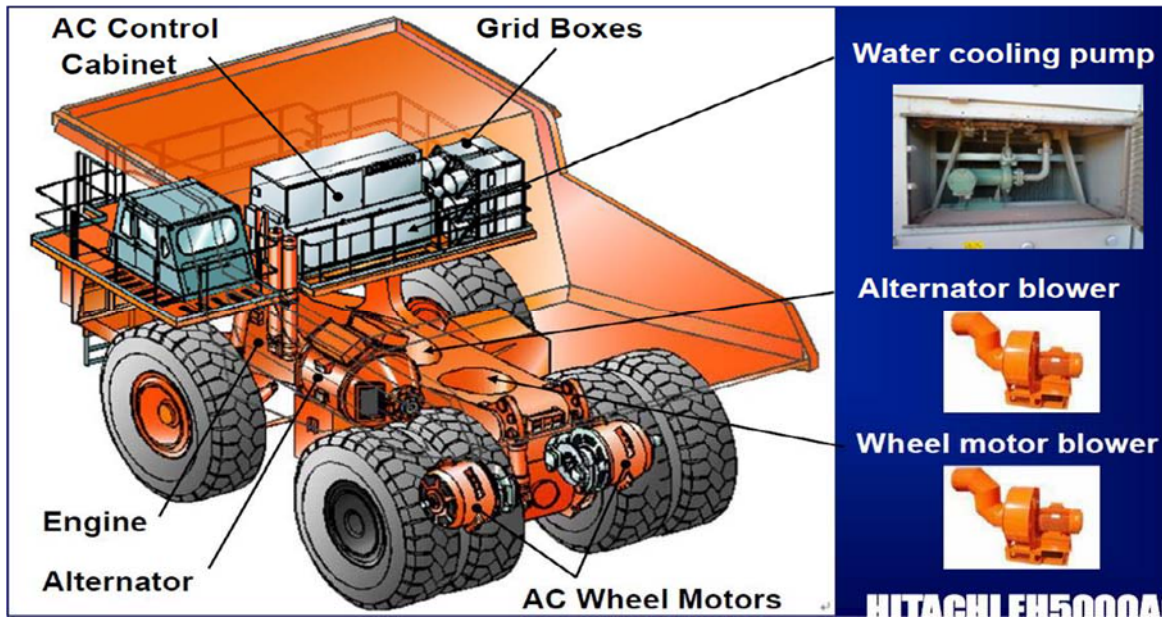

Figure 10: Water pump cooled system on truck

#### SEPARATING CMWS FROM DUST GENERATING TASKS (SEPARATION)

- Barriers to contain dusts from entering the working environment:
  - Install a physical barrier at the enclosure opening while using compressed air to clean electrical components. The enclosure should be maintained under negative pressure by using extraction ventilation with HEPA filtration to capture respirable dusts liberated from the cleaning activity.
  - The enclosure should be adequately sealed to ensure negative pressure is maintained.
  - Establish and apply clearance times to ensure airborne dusts have been removed from the enclosure before the barrier is removed.
  - These tasks should be supported by a safe work instruction.



Photo 31: Separation screens between dust generating activity and CMW (electrical cabinets)



Photo 32: Separation screens between dust generating activity and CMW (electrical cabinets)





Photo 33: Separation screens between dust generating activity and CMW (electrical cabinets)

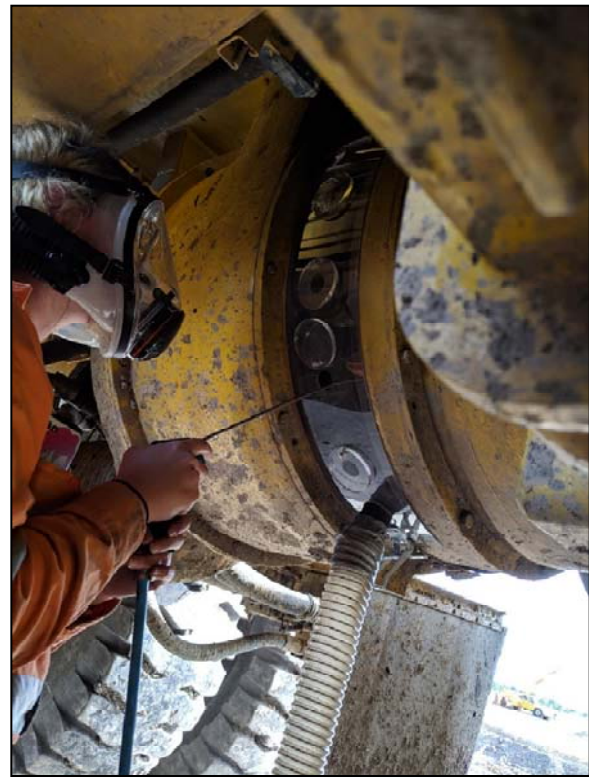

Photo 34: Separation screens between dust generating activity and CMW (alternator)

#### Modifying the work method process (Substitution)

- Pre-vacuum (e.g. Using Vac-truck or portable vacuum system) prior to compressed air cleaning.
- Use HEPA Class vacuum cleaners for removing dust deposits.

#### ADMINISTRATIVE CONTROLS TO LIMIT EXPOSURE DURATION AND INTENSITY (ADMINISTRATION)

- Once the blowout is finished, allow adequate clearance time for any airborne dust to settle before allowing other CMWs to enter the workshop.
- A real-time monitor may be used to compare and verify pre & post dust levels for clearance monitoring.

#### ADMINISTRATIVE CONTROLS TO LIMIT NUMBER OF CMWS EXPOSED (ADMINISTRATION)

- Apply exclusion zones / times to remove all CMWs not directly involved in the task from the truck during blowout.
- Remove CMW's from the work area so exposure to airborne dust is reduced or eliminated. Using compressed air through work breaks so CMW's not directly involved with this task are completely removed.
- Consideration to be given to truck positioning on maintenance days in relation to other occupied areas (e.g. Crib huts).

#### PROTECTING THE WORKER'S BREATHING ZONE WITH RESPIRATORY PROTECTIVE EQUIPMENT (RPE).

- Ensure all RPE complies with AS/NZS 1716 (7).
- Use a minimum of PAPR or supplied – air respiratory protection when using compressed air for cleaning without the use of extraction.



## MAINTENANCE OF CONTROLS

- Implement a maintenance and inspection schedule for the filtration system to ensure it achieves design performance and OEM performance requirements.
- Maintenance triggers should be established based on performance monitoring (e.g. pressure / OEM specifications).
- Scheduled inspection and maintenance of RPE to OEM requirements.

## Appendix 5: Ingress Protection (IP) Ratings

First Digit	Intrusion Protection	Second Digit	Moisture Protection
0	Non-protected	0	Non-protected
1	Protected against solid foreign objects of 50 mm and greater	1	Protected against vertically falling water drops
2	Protected against solid foreign objects of 12.5 mm and greater	2	Protected against vertically falling water drops when enclosure tilted up to 15 degrees
3	Protected against solid foreign objects of 2.5 mm and greater	3	Protected against spraying water
4	Protected against solid foreign objects of 1.0 mm and greater	4	Protected against water jets
5	Dust protected	5	Protected against the effects of temporary immersion in water
6	Dust-tight	6	Protected against the effects of continuous immersion in water

AS60529: Degrees of protection provided by enclosures (extracted from Section 4.2 of the Standard) (6)

# Appendix 6: Example of Dragline Cleaning Process / Sequencing

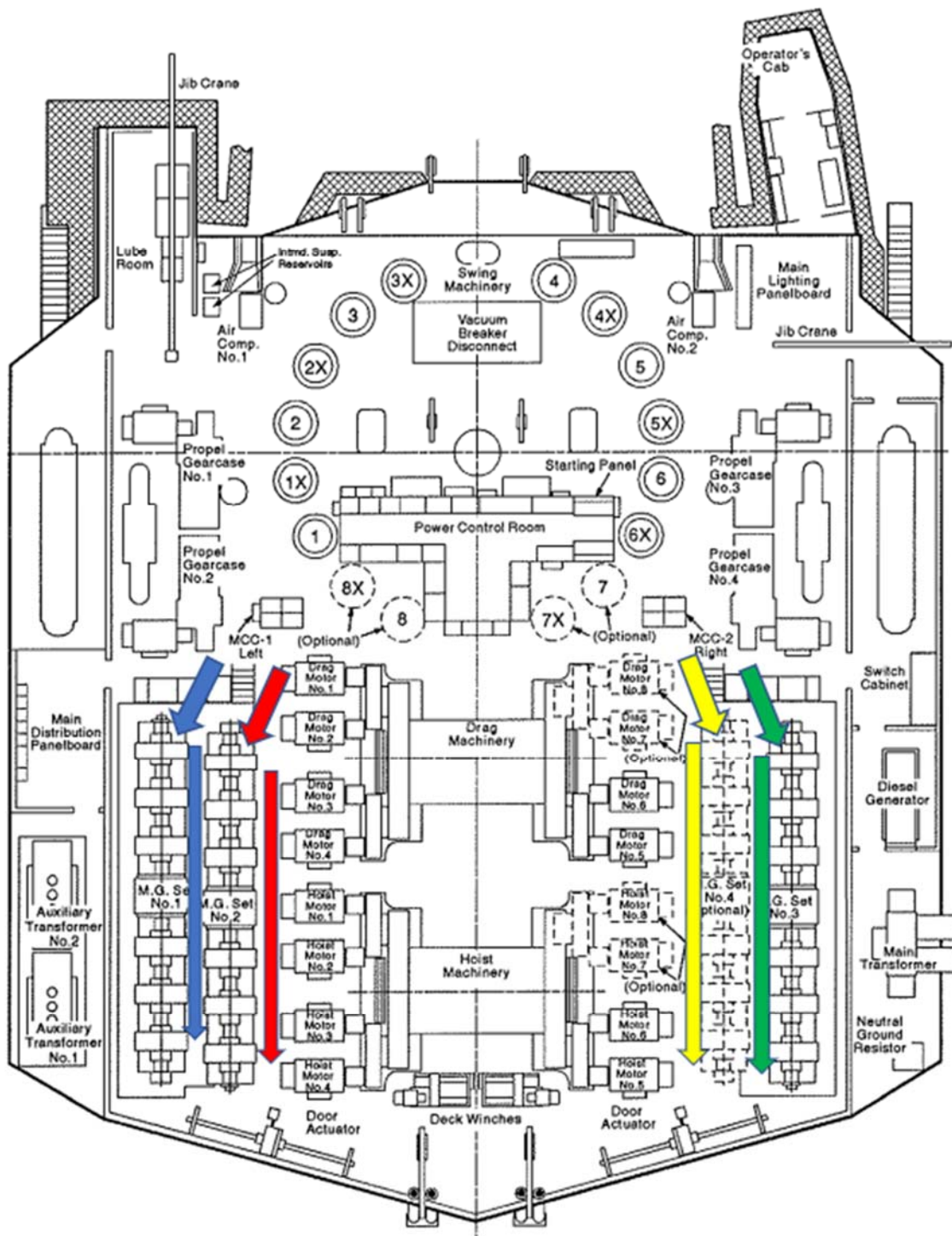

Blow out in the order.



## Appendix 9: Abbreviations

<b>CHPP</b>	Coal Handling Preparation Plant
<b>CMSHA</b>	Coal Mining Safety and Health Act 1999
<b>CMSHR</b>	Coal Mining Safety and Health Regulation 2017
<b>CMW</b>	Coal Mine Worker
<b>HEPA</b>	High Efficiency Particulate Air [filter]
<b>HME</b>	Heavy Mobile Equipment
<b>MDLD</b>	Mine Dust Lung Disease
<b>OEL</b>	Occupational Exposure Limit
<b>OEM</b>	Original equipment manufactures
<b>PAPR</b>	Powered Air Purifying Respirators
<b>pLEV</b>	Portable local exhaust ventilation
<b>RCD</b>	Respirable Coal Dust
<b>RCS</b>	Respirable Crystalline Silica
<b>RPC</b>	Reactive Power Compensator
<b>RPE</b>	Respiratory Protective Equipment
<b>RSHQ</b>	Resources Safety and Health Queensland
<b>RS14</b>	Recognised Standard 14
<b>RS20</b>	Recognised Standard 20
<b>SEG</b>	Similar Exposure Group
<b>SHMS</b>	Safety and Health Management System

## Reference List:

1. **DNRME.** *Recognised Standard 20 – Dust Control in Surface Coal Mines*. Retrieved from [https://www.rshq.qld.gov.au/\\_\\_data/assets/pdf\\_file/0005/1462685/recognised-standard-20-dust-control-surface-mines.pdf](https://www.rshq.qld.gov.au/__data/assets/pdf_file/0005/1462685/recognised-standard-20-dust-control-surface-mines.pdf). : *Coal Mining Safety and Health Act 1999*, 2019.
2. **Queensland Legislation.** *Coal Mining Safety and Health Act 1999*. s.l. : Office of the Parliamentary Counsel, current as of 1 March 2023.
3. **Queensland Legislation.** *Coal Mining Safety and Health Regulation 2017*. s.l. : Queensland Parliamentary Council, current as of 13 December 2023.
4. **Resources Safety & Health Queensland.** *Recognised Standard 14: Monitoring respirable dust in coal mines*. Retrieved from: <https://www.rshq.qld.gov.au/resources/documents/mines-resources/safety-and-health/legislation,-standards-and-guidelines/recognised-standards-coal-mines/recognised-standard-14.pdf> : *Coal Mining Safety and Health Act 1999*, 2021.
5. **Australian Standard.** *AS 2985 - Workplace Atmospheres - Method for sampling and gravimetric determination of respirable dust*. Sydney : Standards Australia, 2009.
6. **Australian Standard.** *AS 60529 - Degrees of protection provided by enclosures (IP Code)*. Sydney : Standards Australia , 2004.
7. **Australian Standard.** *AS/NZS 1716 - Respiratory Protective Devices*. Sydney : Standards Australia, 2012.
8. **Australian Standard.** *AS/NZS 1715 - Australian Standard: Selection, use and maintenance of respiratory protective equipment*. Sydney, NSW. : Standards Australia, 2009.
9. **Manser, B and Maxwell, N.** *Dragline Machine House Cooling and Dust Control - C15030*. Brisbane : ACARP, 2007.
10. **Manser, B and Costello, M.** *Dragline Machine House Dust Control - C17034*. Brisbane : ACARP, 2009.